

Table of Contents

Table of Contents	1
1.0 Induction	3
2.0 Specifications	4
2.1 Supporting Projected Capacitive touch panel size.....	4
2.2 Interface: USB, UART, I ² C.....	4
2.3 Max Touch Line	4
2.4 Sampling rate	4
2.5 Operating Voltage	4
2.6 Power Consumption	4
2.7 RS specification	4
2.8 CS specification	4
2.9 Operating temperature.....	4
2.10 Storage temperature.....	4
3.0 Mechanical Drawing	5
3.1 Mechanical size.....	5
3.2 Touch line pin definition	6
3.3 Interface pin definition	7
4.0 Drivers and Utilities	10
4.1 Drivers.....	10
4.2 Utilities.....	10
5.0 Others	11
5.1 ROHS compliance.....	11
5.2 EMC protection recommendations	11
5.3 Noise Protection	11

Revision History

Rev.	Date	By	Summary	Remark
1.0	2014/08/18	Ken Hsu	New release	
1.1	2015/01/09	Ken Hsu	Add the EMC certification data	
1.2	2016/01/21	Ken Hsu	EMC certification Level modified Correct item 3.3 Interface pin definition	
1.3	2016/08/24	Ken Hsu	Correct item 3.3 Interface pin definition	

1.0 Induction

The PenMount PM2300 control board is a high specification (Projected Capacitive Input, PCI) touch panel controller product introduced by PenMount. The PenMount PM2300 can be applied in the consumer, commercial and the industrial fields.

The PenMount PM2300 provides three types of interfaces, USB, UART and I²C and supports PCI touch panels sized from 8" to 10.4". PenMount PM2300 also supports a wide range of operating systems such as Windows and Linux.

The PenMount PM2300 was developed based on Microchip microprocessors and is paired with PenMount's in-house hardware design and firmware algorithmic mechanism. It provides high performance computing and possesses excellent anti-noise capabilities.

2.0 Specifications

2.1 Supporting Projected Capacitive touch panel size

Projected capacitive type, from 8" to 10.4"

2.2 Interface: USB, UART, I²C

USB: Full-speed, 12Mbps

UART: 38400 baud rate / 8bit data / non parity / one stop bit / non-PnP

I²C: I²C Slave, support 100 / 400 kHz specifications

2.3 Max Touch Line

35 Driving lines (Tx), 24 Sensing lines (Rx)

2.4 Sampling rate

One Finger touch 150 sps / Five Fingers touch 100 sps

2.5 Operating Voltage

+3.3Vdc ~ +5Vdc, ±5 %

2.6 Power Consumption

Working Mode : 41.7mA @ 5Vdc, Idle Mode : 21.9mA @ 5Vdc, Sleep Mode : 2.5mA @ 5Vdc

2.7 RS specification

IEC61000-4-3 Level 3 , Criteria A

2.8 CS specification

IEC61000-4-6 Level 3 , Criteria A (For 1.8mm)

2.9 Operating temperature

-20°C ~ +70°C

2.10 Storage temperature

-40°C ~ +85°C

Note :

Power consumption and sample rate will vary according to different firmware versions.

3.0 Mechanical Drawing

3.1 Mechanical size

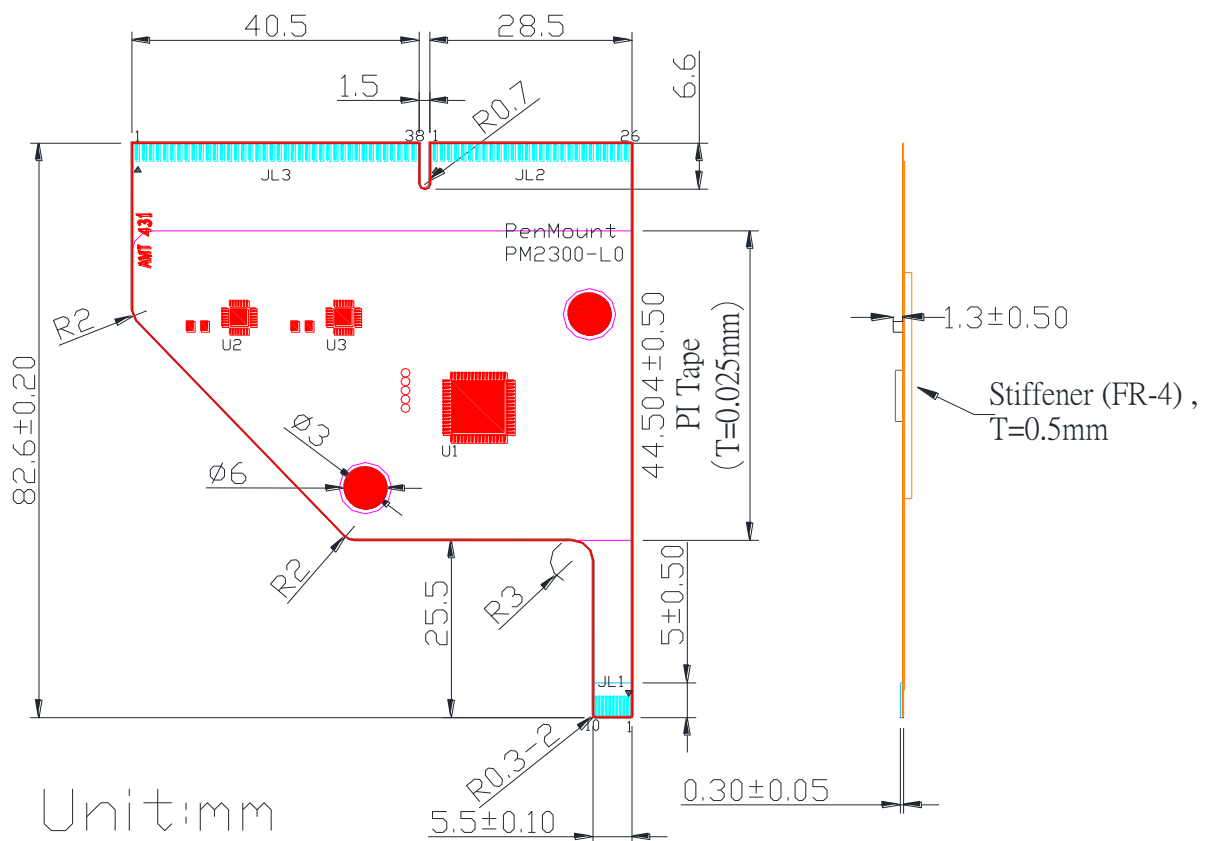
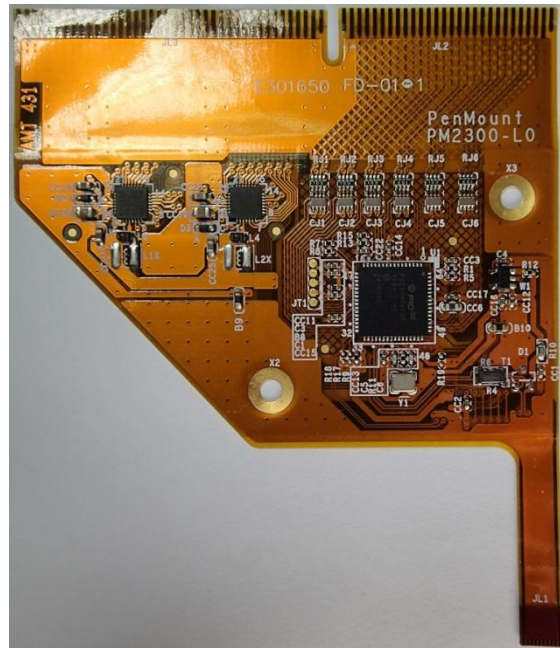

3.2 Touch line pin definition

JL2							
Pin	Description	Pin	Description	Pin	Description	Pin	Description
1	GND	8	Cap Sense Y17	15	Cap Sense Y10	22	Cap Sense Y3
2	Cap Sense Y23	9	Cap Sense Y16	16	Cap Sense Y9	23	Cap Sense Y2
3	Cap Sense Y22	10	Cap Sense Y15	17	Cap Sense Y8	24	Cap Sense Y1
4	Cap Sense Y21	11	Cap Sense Y14	18	Cap Sense Y7	25	Cap Sense Y0
5	Cap Sense Y20	12	Cap Sense Y13	19	Cap Sense Y6	26	GND
6	Cap Sense Y19	13	Cap Sense Y12	20	Cap Sense Y5		
7	Cap Sense Y18	14	Cap Sense Y11	21	Cap Sense Y4		

JL3							
Pin	Description	Pin	Description	Pin	Description	Pin	Description
1	GND	11	Cap Drive X8	21	Cap Drive X18	31	Cap Drive X28
2	GND	12	Cap Drive X9	22	Cap Drive X19	32	Cap Drive X29
3	Cap Drive X0	13	Cap Drive X10	23	Cap Drive X20	33	Cap Drive X30
4	Cap Drive X1	14	Cap Drive X11	24	Cap Drive X21	34	Cap Drive X31
5	Cap Drive X2	15	Cap Drive X12	25	Cap Drive X22	35	Cap Drive X32
6	Cap Drive X3	16	Cap Drive X13	26	Cap Drive X23	36	Cap Drive X33
7	Cap Drive X4	17	Cap Drive X14	27	Cap Drive X24	37	Cap Drive X34
8	Cap Drive X5	18	Cap Drive X15	28	Cap Drive X25	38	GND
9	Cap Drive X6	19	Cap Drive X16	29	Cap Drive X26		
10	Cap Drive X7	20	Cap Drive X17	30	Cap Drive X27		

3.3 Interface pin definition

PM2300 includes USB/I2C/UART communication interfaces, intends to maximize application flexibility and reliability, and minimizes cost through elimination of external components.

JL1				
PIN NO.	SYMBOL	PIN ASSIGNMENT		
		USB	I ² C	UART
1	VCC	VCC	VCC	VCC
2	D-	D-	N.C.	N.C.
3	D+	D+	N.C.	N.C.
4	GND	Ground	Ground	Ground
5	SCL / RXD	N.C.	SCL	RXD
6	SDA / TXD	N.C.	SDA	TXD
7	nRESET	N.C.	N.C.	N.C.
8	nDetect	N.C.	Low	Low
9	nINT	N.C.	nINT	Low
10	N/A	N.C.	N.C.	N.C.

Note: N.C. is No Connection

Pin Name	Type	Description
VCC	P	Positive power supply
GND	P	Ground
D-	I/O	D- pin of internal USB transceiver
D+	I/O	D+ pin of internal USB transceiver
SCL	I/O	Serial data line for I2C. Open drain requires external pull-up to VCC
SDA	I/O	Serial clock line for I2C. Open drain requires external pull-up to VCC
RXD	I	UART receive
TXD	O	UART transmit
nRESET	I	Open-drain and active low to reset PM2300 and must be driven low for 5 μ s (typical) to be valid. Leave the pin unconnected if not used.
nDETECT	I	Pull low when selecting I2C or UART interface
nINT	O	Processor Interrupt. This pin is active low, open drain, and should be pulled high to VCC
N/A		Not applied

USB

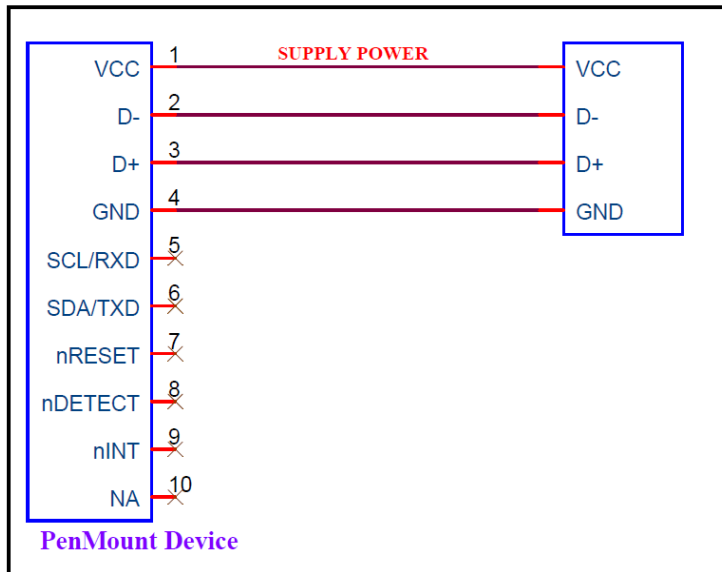

Figure 1. USB interface

UART

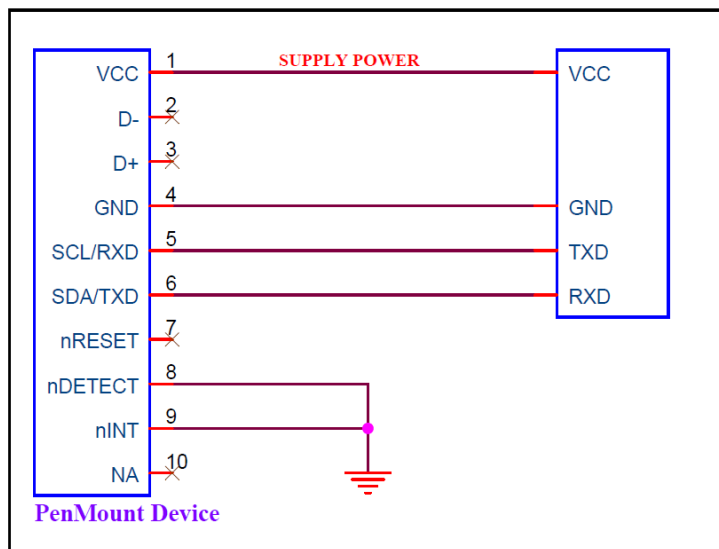

Figure 2. UART interface

I2C

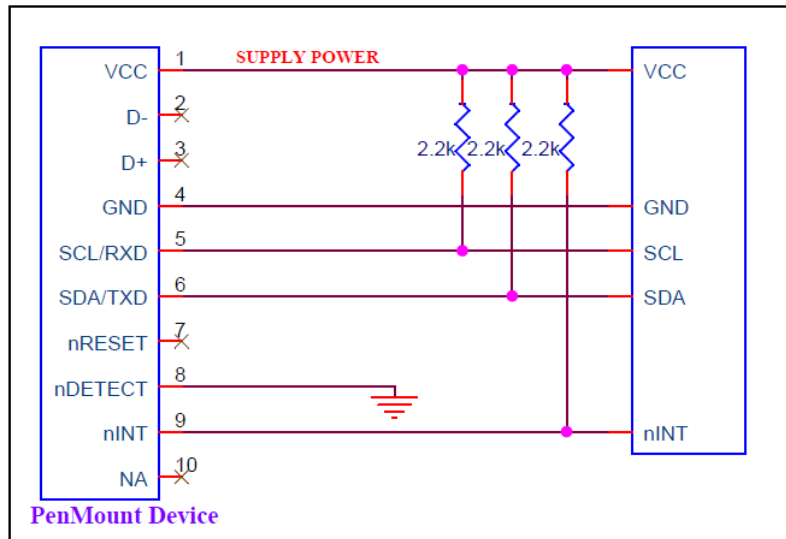

Figure 3. I2C interface

4.0 Drivers and Utilities

4.1 Drivers

For I²C:

- Windows CE : Provide binary driver for freescale iMX platform. Other platform by request.
- Linux / Android : Provide source code for integration.

For USB and UART

- Windows 2000, XP, 2003: single touch, mouse driver.
- Windows Vista: single touch, inbox driver.
- Windows 7,8,10: five touch, Inbox driver.
- Linux: Ubuntu, Android, other Linux distributions under development.

(Provide source code for integration if any)

4.2 Utilities

Firmware adjustment utility allows user to fine tune the touch panel sensitivity.

Note:

Drivers, Utilities: all drivers are available on PenMount websites. PenMount utilities are also available, please contact us.

5.0 Others

5.1 ROHS compliance

This control board is ROHS compliant

5.2 EMC protection recommendations

Please refer to PCI touch screen integration guides.

5.3 Noise Protection

To achieve good noise interference protection capabilities, PenMount requires paired interface cables possess comprehensive EMI shielding.